

DIMENSIONS

DF140BG/DF115BG
DF140B/DF115B

Unit: mm

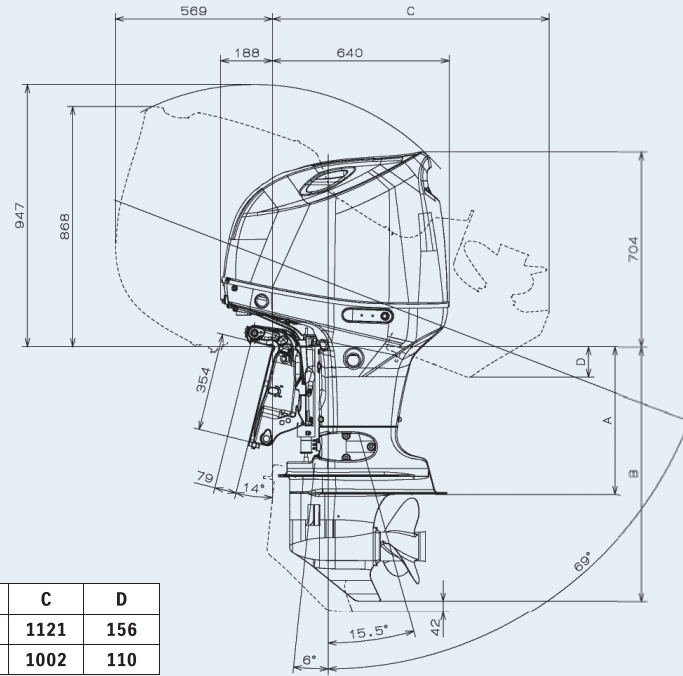

Dimension	A	B	C	D
TRANSOM:X	661	1047	1121	156
TRANSOM:L	534	920	1002	110

FEATURE & SPEC SHEET

FEATURES	DF140BG DF115BG	DF140B DF115B
BODY COLOR	BLACK	●
	WHITE	●
SUZUKI PRECISION CONTROL (S.P.C.)	●	●
NEW DYNAMIC & SMOOTH DESIGN	●	●
RESONATOR INTEGRATED WITH THE SILENSER	●	●
OFFSET DRIVE SHAFT	●	●
2-STAGE GEAR REDUCTION SYSTEM	●	●
NEW DESIGNED AIR INTAKE SYSTEM	●	●
SUZUKI WATER DETECTING SYSTEM	●	●
SUZUKI LEAN BURN CONTROL SYSTEM	●	●
UPGRADED COMPRESSION RATIO	●	●
UPGRADED VENTILATION FUNCTION	●	●
EASY ACCESS OIL FILTER	●	●
EASY ACCESS FUEL FILTER	●	●
OIL SPILL CATCHER	●	●
USABLE OIL LEVEL GAUGE	●	●
DUAL ENGINE FLUSH PORT	●	●
DIRECT IGNITION	●	●
SELF-ADJUSTING TIMING CHAIN	●	●
OPTIMIZED O ₂ SENSOR MOUNTING POSITION	●	●
LARGE CAPACITY FUEL PUMP	●	●
ZINC-CONTAINING RUSTPROOF COATING BOLT	●	●
AUTOMATIC TRIM	○	○
SUZUKI TROLL MODE SYSTEM*1	○	○
TILT LIMIT SYSTEM	●	●
SUZUKI ANTI-CORROSION SYSTEM	●	●
SDSM*2	○	○
KEYLESS START SYSTEM*2	○	○
SUZUKI EASY START SYSTEM	●	●
OVER REV LIMITER	●	●
LOW OIL PRESSURE CAUTION	●	●

SPECIFICATIONS	DF140BG DF115BG	DF140B DF115B
STARTING SYSTEM	Electric	
RECOMMENDED TRANSOM HEIGHT (mm)	L:508 / X:635	
WEIGHT (kg)	DF140BG: L 188 / X 192 DF115BG: L 190 / X 194	DF140B: L 186 / X 190 DF115B: L 188 / X 192
VALVE TRAIN	DOHC 16-Valve	
FUEL DELIVERY SYSTEM	Multi-Point Sequential Electric Fuel Injection	
NO. OF CYLINDERS	4	
DISPLACEMENT (cm ³)	2,045	
MAXIMUM OUTPUT (kw)	DF140BG&B: 103 DF115BG&B: 84.6	
COMPRESSION RATIO	10.6	
BORE x STROKE (mm)	86 X 88	
OPERATION RANGE (rpm)	DF140BG&B: 5,700-6,300 DF115BG&B: 5,000-6,000	
STEERING	Remote	
OIL PAN CAPACITY (L)	5.5	
ALTERNATOR	12V 40A*	
TRIM TYPE	Power Trim and Tilt	
ENGINE MOUNTING	Shear Mount	
GEAR RATIO	2.59 : 1	
CONTROL SYSTEM	Digital	Mechanical
RECOMMENDED FUEL	RON91, AKI87	
PROPELLER SELECTION (PITCH)	15"-25"(RR) 17"-23"(CR)	

*3Amp up at idle

● : Standard ○ : Optional

*1: Available with SMD, SMG4, or Troll Mode Switch Panel

*2: Available with SMD or SMG4



Suzuki Marine USA, LLC
13521 Prestige Place, Tampa FL 33635
www.suzukimarine.com

PRODUCT INFORMATION DF140B/115B



High Performance & User Friendly 140B/115B Models

Easy Maintenance

- Designed for customers to maintain easily

Advantage

- Easy access oil filter:
Can be replaced simply by removing the top cover
- Oil Spill Catcher:
A tray is added around the oil filter to catch oil which comes out when exchanging the oil filter
- Oil Level Gauge:
Able to use $\Phi 15\text{mm}$ oil changer hose

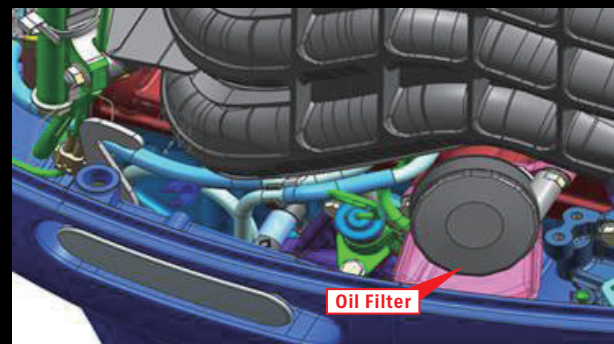

Easy access Oil Filter

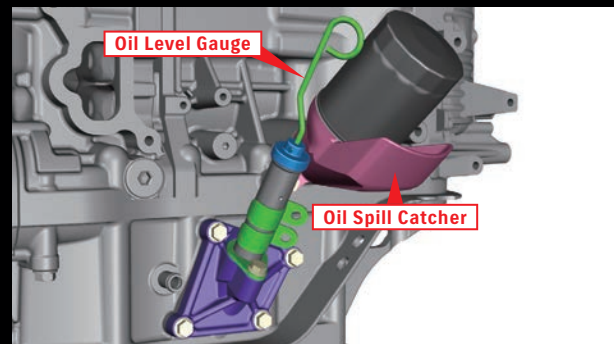

Oil Spill Catcher & Oil Level Gauge



DF140B



DF140B

High Durability

Improved Gear Case

- By optimizing the gear oil passage, the spinning pinion gear generates negative pressure and it helps the gear oil circulate more efficiently.

Advantage

- It lowers gear oil temperature and cools the gear. So this gear case contributes to increasing the durability of pinion gear.

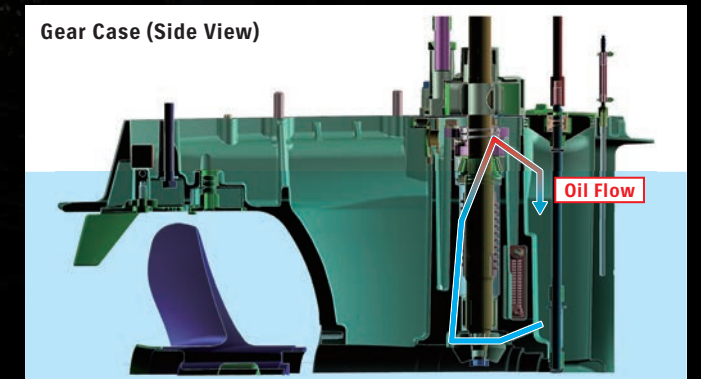
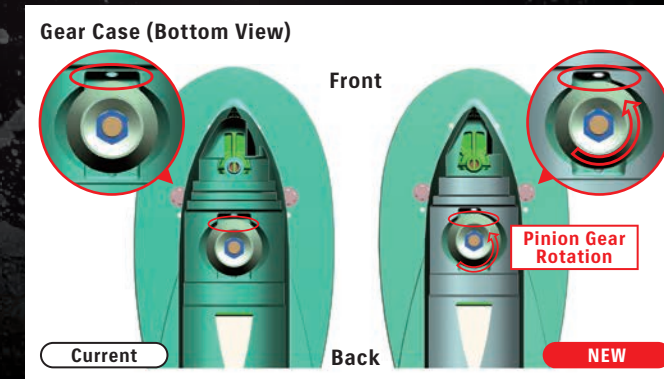

Additional Features for DF140B/115B

- Micro Plastic Collection Device
- Good fuel efficiency
- Drive by Wire controls (optional - PY2022 or later)*1
- Keyless start system & Automatic Trim are available (optional*2)

*1 Suzuki Precision Control is a digital remote controller on the BG models.

*2 Available with SMD (Suzuki Multi-Function Display) or SMG4 (Suzuki Multi-Function Gauge).



Dynamic & Smooth Design

Special Features For DF140B/115B

Suzuki Micro Plastic Collection Device

- Collect and remove micro-plastic particles from the marine environment simply by using your outboard motor
- Does not sacrifice engine performance or risk motor damage

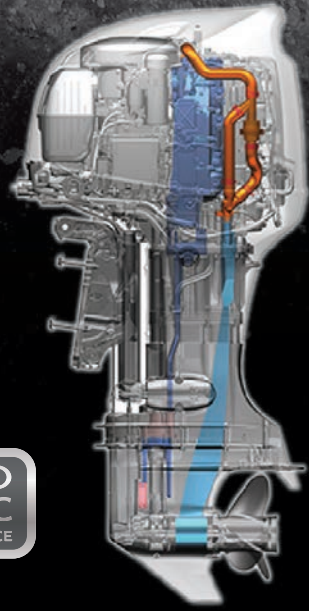
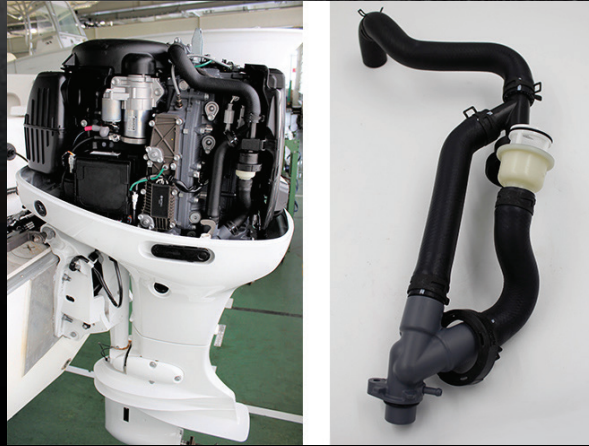

Suzuki Precision Control (S.P.C.)*

- Operation from the remote control is delivered to outboard via an electric signal and not by the traditional mechanical control cables.
- Available to control up to 6 engines.
- Easy start for multi-engine boats
Users can start and stop multiple engines with one button push. Outboards start in order from port to starboard.
- 1 Lever Operation
This switch allows multiple motor operation with only 1 lever (Dual top mount only).
- Automatic Trim can be used with the equipment of SMG4/SMD.

*1 Suzuki Precision Control is a digital remote controller on the BG models - PY 2022 Models and later.



Remote Control Boxes

Single Top Mount



Dual Top Mount

Suzuki Keyless Start System

- Start engine with access code transmitted from keyless fob
- No ignition key necessary.
- How to use
 1. Stand nearby the console with the key fob.
 2. Press the start button and you are ready to go!



Keyless Fob

The Ultimate Boating Experience is Here with DF140B/115B



DURABILITY & RELIABILITY

New Air Intake System

- Newly designed air intake system separate water from air twice before the air is taken into cowl

Advantage

- The special structure of air intake can increase the ability to remove water from air taken into cowl
- Lower the temperature of the air intake
- Delivers higher power output

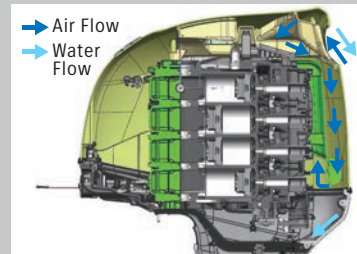

Direct Ignition

- Integrates the ignition coils into the spark plug caps

Advantage

- Reduces the number of parts and simplifies the wiring system
- Removing the high tension cord enables the ignition to generate spark efficiently which leads to the improvement of combustion efficiency

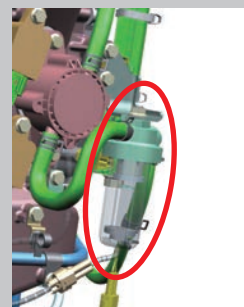
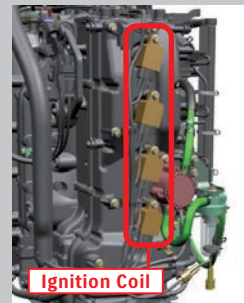

Bigger Fuel Filter

Water Detecting System



- It helps to protect the engine from water in the fuel
- Uses a larger fuel filter than the DF140A/115A
- Optimized Fuel Filter position

Advantage

- Traps water before it can enter the engine
- Increased durability & reliability
- Easy replacement of fuel filter

More Features to contribute to Durability

- Large capacity Fuel Pump: Capable of being rigged on multiple types of vessels
- Optimized O₂ Sensor mounting position: Increased Durability
- Using Zinc-containing Rustproof Coating bolt: Increased Durability

EASE & COMFORT

Quiet Operation



- Intake noise is suppressed with a resonator, which makes the noise from the outboard quieter.

Advantage

- Less noise, making boating more pleasant.

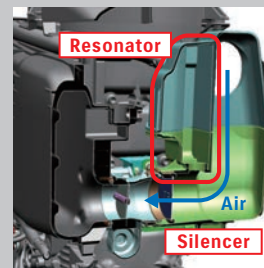

Alternator Output

- Newly designed ventilation which cools the coils better

Advantage

- 3Amp better alternator output at idle speed range that is roughly equivalent to the necessary output to operate SMD12/SMD16.

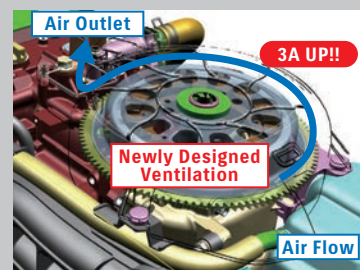

PERFORMANCE

High Compression Ratio

- To achieve the optimized shape of parts, we simulated over 1,000 combinations and tested thoroughly with carefully selected parts.

Advantage

- Achieved 10.6 Compression Ratio which contributes to high torque.

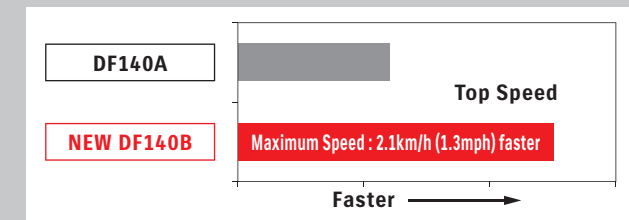

*Data in the graph is based on "In-House Suzuki Testing" under uniformed conditions. Results will vary depending upon operating conditions (boat design, size, weight, weather, etc.).

Offset Drive Shaft



- The engine powerhead is positioned closer to the front, moving the outboard's center of gravity forward.

Advantage

- Less vibration
- More compact
- Stable steering performance

2-Stage Gear Reduction



- This system which incorporates the Offset Driveshaft features a first stage reduction between the crankshaft and drive shaft, and a second stage reduction inside the gear case.

Advantage

- High Torque even with big loads.
- Powerful enough to rotate larger propeller

ECOLOGY & ECONOMY

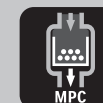

Micro Plastic Collection Device

DF140B/115B

NEW

As one of the actions in SUZUKI CLEAN OCEAN PROJECT, we developed the device to collect micro-plastics in the oceans just by running SUZUKI's outboard motors.

ADVANTAGE :

- Collect micro-plastics through your outboard motors.
- Does not sacrifice engine performance or risk damage.

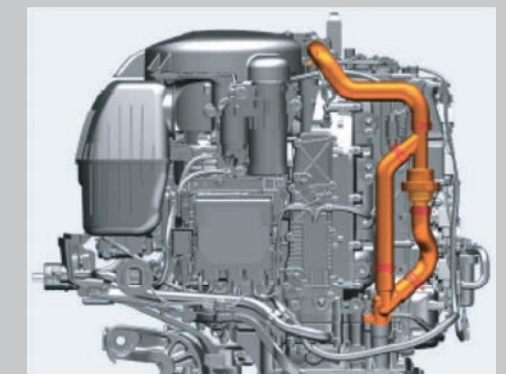

Lean Burn Control System

LEAN BURN

- The Lean Burn Control System supplies the appropriate amount of fuel and air mixture depending on the navigation conditions.

Advantage

- Significant improvement in fuel economy in all speed ranges especially at cruising speed.
- Fuel is saved and gasoline costs are cut thanks to improved fuel economy.