

A photograph of four Suzuki outboard motors mounted on a boat, moving through water. The motors are dark grey with 'SUZUKI' and '350' printed on them. The boat is white with 'FITZGERALD FISHING' and 'TREMONT' visible on its side. The background shows a blurred shoreline with trees under a bright sky.

SUZUKI MARINE OUTBOARD MOTORS

FULL LINE CATALOG

The Suzuki Marine logo, featuring a red and white stylized 'S' symbol to the left of the text 'SUZUKI' in blue and 'MARINE' in white on a blue rectangular background.

SUZUKI
MARINE

THE
ULTIMATESM
OUTBOARD MOTOR

SUZUKI CLEAN OCEAN PROJECT

As the world's ULTIMATE OUTBOARD MOTOR brand, Suzuki always remains focused on providing the ultimate marine experience, which requires a healthy and clean marine environment.

Since 2011, we have been voluntarily conducting the "Clean-Up the World Campaign" every year to contribute to a better marine environment and more than 19,000 people have participated. In Japan, the campaign has been officially recognized by the Ministry of the Environment in the "Plastic Smart Campaign".

To continue to make our utmost effort for environmental protection, it is now time for us to review how we have been contributing to the environment and society and newly determine our direction. As well as continuing our worldwide clean-up campaign, we will also commit to take responsible actions against plastic waste problems. This is how we came to make the new Slogan and Logo, "SUZUKI CLEAN OCEAN PROJECT", to show the world our commitment.

Our Commitment

1. Clean-Up the World Campaign
2. Reduce Plastic Packaging
3. Collect Marine Micro-Plastic Waste



We believe the actions Team Suzuki takes around the world will be one positive step forward to a cleaner marine environment.

CONTENTS

- 4-5 **SUZUKI CLEAN OCEAN PROJECT**
- 6-11 **SUZUKI ULTIMATE TECHNOLOGY**
- 12-13 **STEALTH LINE™ SERIES**
 - DF350 STEALTH
 - DF300 STEALTH **NEW**
 - DF250A/DF250 STEALTH
 - DF200/150 STEALTH
 - DF140B/115B STEALTH
- 14-15 **GEKI: 350-300HP FLAGSHIP**
 - DF350AMD/300BMD
 - DF350A/300B
- 16-17 **V6 300-200HP**
 - DF300AP/250AP
 - DF250/225/200
- 18-19 **IN-LINE 4 200-150HP**
 - DF200AP/175AP/150AP
 - DF200A/175A/150A
- 20-21 **IN-LINE 4 140-75HP**
 - DF140BG/115BG
 - DF140B/115B
 - DF90A/75A
- 22-23 **IN-LINE 3 60-25HP**
 - DF60AV/50AV
 - DF60A/50A/40A
 - DF30A/25A
- 24-25 **PORTABLE 20-2.5HP**
 - DF20A/15A/9.9B
 - DF6A/4A
 - DF2.5
- 26-28 **PARTS & ACCESSORIES**
- 29 **ECSTAR/SYNCRO EYE**
- 30-33 **SPECIFICATIONS & FEATURES**
- 34-35 **HISTORY**



SUZUKI CLEAN OCEAN PROJECT

In order to clean the ocean, the Suzuki Marine Team will promote the "SUZUKI CLEAN OCEAN PROJECT" together with partners and boaters all around the world.

To reduce marine plastic pollution, Suzuki has set up the slogan "CLEAN OCEAN PROJECT" and has been promoting the activities under the 3 commitments.

CLEAN-UP THE WORLD CAMPAIGN

More than **19,000** people from **94** groups participated in this activity.*



PT SUZUKI INDOMOBIL SALES



KGK MOTOR AB



SUZUKI AUSTRALIA PTY. LTD.



NAJEEB AUTO (MARINE)



SUZUKI MARINE USA, LLC



MAGYAR SUZUKI CORPORATION LTD.



TRADER, S.A. DE C.V.

*As of June, 2024

REDUCE PLASTIC PACKAGING

In order to avoid to produce additional plastics, we have been replacing the plastic packaging of outboards and marine genuine parts to eco-conscious materials.

Packaging for Suzuki marine genuine parts



■ Oct.2020 – June.2024 : Reduced **26.1t.**

Replacing the plastic packaging to biodegradable material.

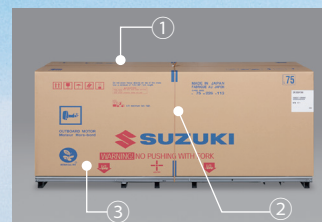

■ Sep.2021 – June.2024 : Reduced **41.1t.**

- ① OPP Tape
Polypropylene → Paper
- ② Outer Fixing Band
Polypropylene → Paper
- ③ Ink (for all the ink on the carton)
Animal-derived ink → Botanical Ink
- ①, ④, ⑤ Fixing Form
Polystyrene Foam → 100% biomass-derived polymers
- ② Upper Engine Cover Sheet
Nylon → Rayon
- ③ Engine Cover Sheet
Polypropylene → 100% biomass-derived polymers
- ⑥ Inner Fixing Band
Polypropylene → Paper

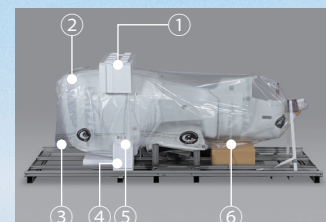

COLLECT MARINE MICRO-PLASTIC WASTE

As a solution to the plastics flowing into the oceans, which are not collected properly on land, Suzuki developed the world's first Micro-Plastic Collecting device(MPC) to install outboard motors.

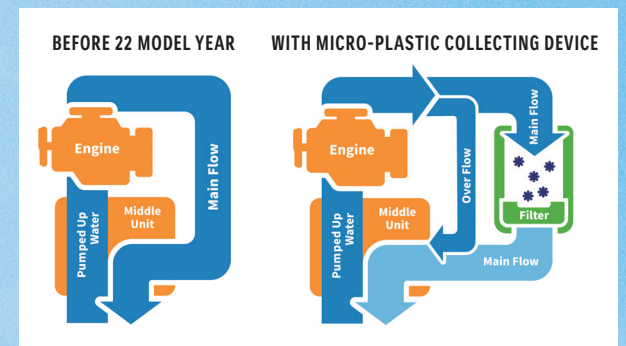
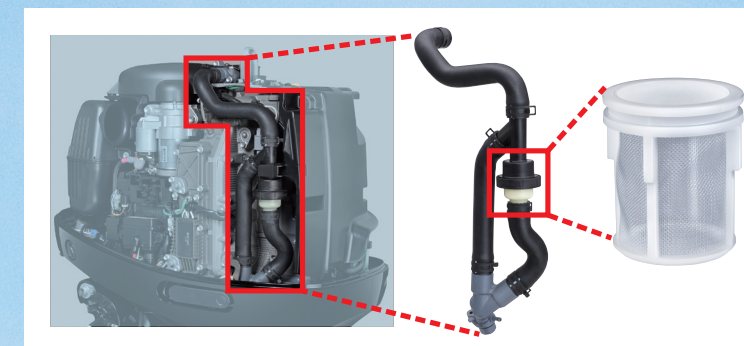

Garbage-contaminated seawater



Micro-Plastic Collecting device makes the sea beautiful

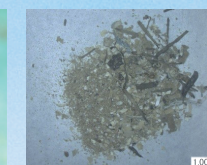

Collected materials

FEATURES

- Will not affect the performance of the engine even if the filter gets clogged since this device utilizes the used cooling water.
- Will not give negative effects on the environment.



DF140BG
DF115BG

DRIVE BY WIRE
with MPC

DF140B
DF115B































MECHANICAL
with MPC



SUZUKI OUTBOARD MOTORS 5

LEADING THE INDUSTRY WITH AWARD WINNING TECHNOLOGIES AND DESIGNS, SUZUKI OUTBOARDS PROVIDE FEATURES AND BENEFITS THAT MAKE BOATING EVEN MORE ENJOYABLE

THE ULTIMATE OUTBOARD MOTOR

Durability & Reliability	Performance	Ease & Comfort	Ecology & Economy
<ul style="list-style-type: none"> • Durable • Notifies user before engine trouble • Easy to service, repair         	<ul style="list-style-type: none"> • Smooth and quick acceleration at all operating ranges • Powerful torque       	<ul style="list-style-type: none"> • Less vibration • Quiet operation • Light & Compact • Easy to use • Smooth and Decisive shifting          	<ul style="list-style-type: none"> • Good fuel efficiency / low exhaust emissions • Low maintenance cost • Environmental protection activities    

Durability & Reliability



SUZUKI DUAL LOUVER SYSTEM

▶DF350AMD/300BMD ▶DF350A/300B

Dog-leg shaped dual louvers remove water from the air directed into the cowling.

ADVANTAGE

- Prevents water intrusion.
- Allows a direct intake system, contributing to higher engine output.



SELF-ADJUSTING TIMING CHAIN

▶DF40A AND UP

The timing chain running in an oil-bath is adjusted automatically by hydraulic tensioner.

ADVANTAGE

- More durable than the belt type.
- Maintenance-free.

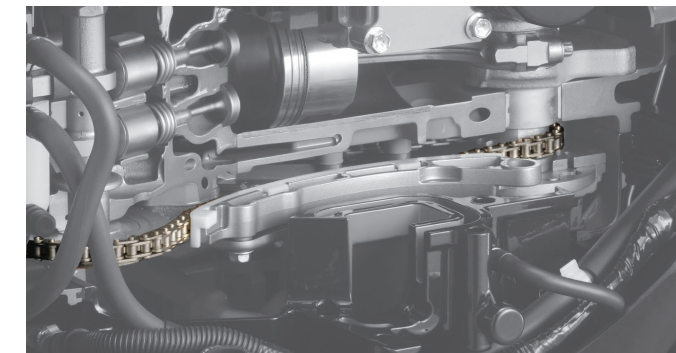

DUAL WATER INLET

▶DF350AMD/300BMD ▶DF350A/300B
▶DF300AP/250AP ▶DF250A/250STEALTH

The engine's cooling system relies on water supplied through two water inlets located on the lower unit.

ADVANTAGE

- Increases the water flow, providing better cooling performance.



WATER DETECTING SYSTEM

▶DF75A AND UP

A water detecting fuel filter system. When water is detected, the system will alert the driver with visual and audio warnings.

ADVANTAGE

- Helps prevent lower power output and corrosion by alerting driver of water intrusion.



TILT LIMIT SYSTEM

▶DF50AV AND UP
(not including DF50A/40A)

Tilt Limit System prevents the outboard from tilting beyond a selected angle.

ADVANTAGE

- Prevents damage to the boat or outboard due to excessive outboard tilting.

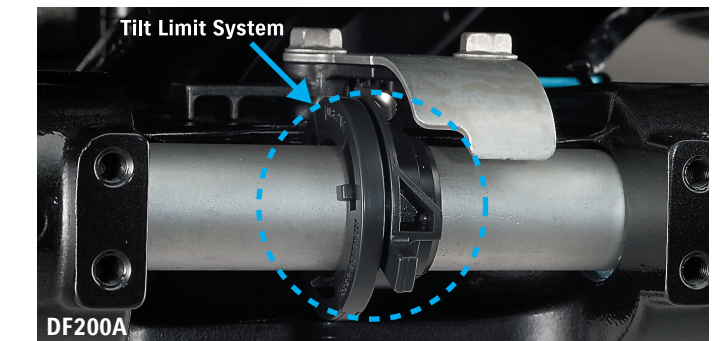

SUB WATER INLET

OPTIONAL: ▶DF140BG/115BG ▶DF140B/115B
STANDARD: ▶DF60A/50A/40A

Two water inlets in different directions ensure that the engine does not overheat due to clogging by sea grass or algae.

NMMA Innovation Awards

The Innovation Awards (recognizing technological innovation) awarded each year by the NMMA (National Marine Manufacturers Association) are considered among the highest honor in marine technology. Of the new marine industry products in that year, they are awarded to "a product that shows technical leadership, is practical and cost-effective, and is truly beneficial to the consumer."

Starting with the DT200 Exanté in 1987 and extending to the DF350A in 2017, Suzuki outboard motors have received this Innovation Award a total of nine times. Eight of these awards are for 4-stroke outboard motors.



Awarded Prizes

1987: DT200 Exanté	2011: DF50A & DF40A
1997: DF70 & DF60	2012: DF300AP
1998: DF50 & DF40	2014: DF30A & DF25A
2003: DF250	2017: DF350A
2006: DF300	



KEYLESS START SYSTEM

- OPTIONAL:**
- ▶ DF350AMD/300BMD
 - ▶ DF300AP/250AP
 - ▶ DF200 V6 DF225/250 with CANbus
 - ▶ DF200A/175A/150A
 - ▶ DF140B/115B
 - ▶ DF350A/300B
 - ▶ DF250A/250STEALTH
 - ▶ DF200AP/175AP/150AP
 - ▶ DF140BG/115BG
 - ▶ DF90A/75A

This system allows you to start multiple engines by placing a key-fob nearby.

- One push Start & Stop for up to 6 outboard motors.
- Waterproof Floating Key Fob.
- Security support with immobilizer.

ADVANTAGE

- Provides high security.
- Ignition key is not required.



SUZUKI ANTI-CORROSION FINISH

- ▶ ALL MODELS

Special protection is applied to the aluminum surface using high strength bonding to protect the aluminum made exterior parts.

ADVANTAGE

- Protection against corrosion helps increase the overall outboard durability.

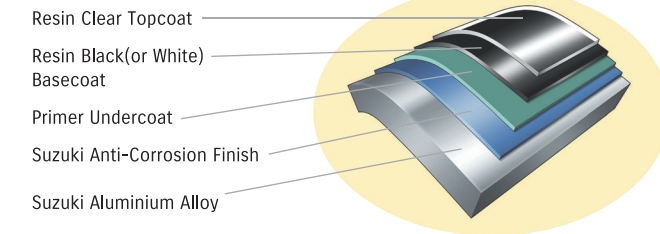

SDSM+ (SUZUKI DIAGNOSTIC SYSTEM MOBILE+)

- ▶ DF9.9B AND UP*

Use the app to plan for boating by checking the weather forecast, the engine condition and operation tips. All functions are available for free.* Please check our website and page 32 for more details.

*SMD/SMG4 and a smartphone running Android/iOS are required.



ADVANTAGE

- Possible to make a plan for boat trip by checking the weather forecast in advance.
- Check up on the engines before the departure based on the engine data.
- Acquire the engine data by scanning the QR code*.
- Provide the engine data to dealer and ask for maintenance easily.

*DENSO WAVE owns the rights of the name and the logo of QR code.

Performance



OFFSET DRIVESHAFT

- ▶ DF75A AND UP

The engine powerhead is positioned closer to the front, moving the outboard's center of gravity forward.

ADVANTAGE

- Less vibration
- More compact
- Stable steering performance

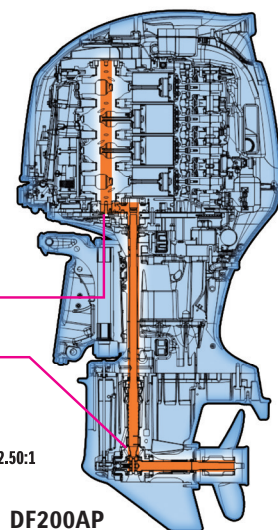

2-STAGE GEAR REDUCTION

- ▶ DF75A AND UP

This design makes a lower gear ratio possible, allowing it to turn a larger diameter higher pitch propeller.

ADVANTAGE

- Increased power to turn large diameter propellers, offering quick acceleration.
- High propulsive efficiency with large diameter propeller.
- Powerful navigation, maintaining propeller rotation even with a larger load.

GEAR RATIO IN EACH CLASS

MODEL	DF140BG/115BG DF140B/115B 90A/75A	DF200A(AP)/ 175A(AP)/150A(AP)	DF250/ 225/200	DF300AP STEALTH DF300AP/250AP/ DF250A STEALTH/ DF250 STEALTH	DF350AMD STEALTH DF350AMD/ 300BMD DF350A/300B
GEAR RATIO	2:59:1	2:50:1	2:29:1	2:08:1	2:29:1



HIGH ENERGY ROTATION

- ▶ DF60AV/50AV

Larger lower units (2.42 gear ratio) make it possible to equip larger 36cm (14-inch) propeller than other models in this class. It offers better acceleration and more power.

ADVANTAGE

- Powerful torque to carry heavy loads.
- Quick acceleration with larger propellers.
- Quick and smooth planing.

DF60AV vs. DF60A size comparison

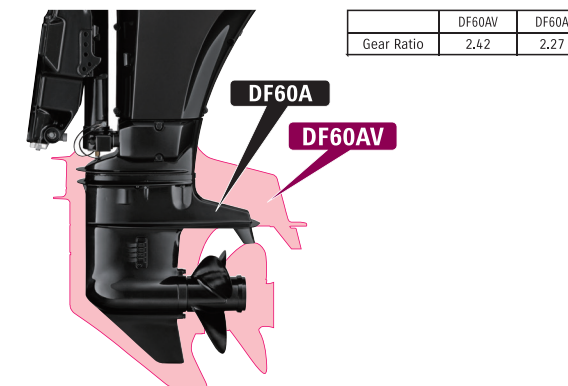

VVT (Variable Valve Timing)

- ▶ DF350AMD/BMD DF350AMD STEALTH ▶ DF350A/300B
- ▶ DF300AP/250AP ▶ DF250A/250STEALTH
- ▶ DF200AP/175AP/150AP ▶ DF200A/175A

The Variable Valve Timing controls the opening and closing timing of the intake valves depending on the engine RPM.

ADVANTAGE

- Offers smooth, powerful torque.
- Provide smooth acceleration across all speed ranges.

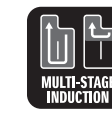
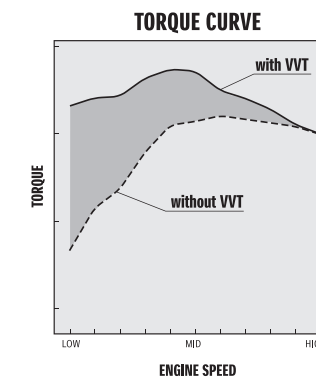

MULTI-STAGE INDUCTION

- ▶ DF250/225 ▶ DF200AP/175AP/150AP
- ▶ DF200A/175A/150A ▶ DF250A/250STEALTH

Intake manifold pipes are switched between short and long during low speed and high speed operation to ensure the right volume of air enters the engine.

ADVANTAGE

- Increases output during high speed operation with greater volume of air input.
- Increases combustion efficiency and maximizes torque during low speed operation.

AIR FLOW IN MULTI-STAGE INDUCTION MODULE

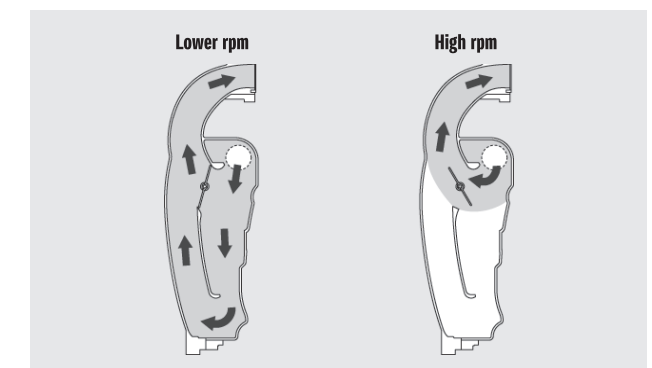

DIRECT AIR INTAKE

- ▶ DF350AMD/300BMD ▶ DF350A/300B

A direct airflow path from the intake port to the cylinder suppresses temperature rise of the air and improves combustion efficiency.

ADVANTAGE

- Delivers higher power output from a small displacement.



SUZUKI DUAL PROP SYSTEM

- ▶ DF350AMD/300BMD ▶ DF350A/300B

The Suzuki Dual Prop System spins two propellers rotating in opposite directions on a single lower unit. With the 6 blades, it can get a better grip on the water.

ADVANTAGE

- Achieve superior stability when driving straight.
- Powerful reverse thrust and braking force.
- Good water gripping performance and quick startup acceleration.

Ease & Comfort



SUZUKI SELECTIVE ROTATION

▶DF300AP/250AP ▶DF300 STEALTH ▶DF200AP/175AP/150AP

Function for selecting regular or counter rotation on one outboard with an optional connector and a counter rotation propeller.

ADVANTAGE

- Either regular or counter rotation can be used on the same outboard.

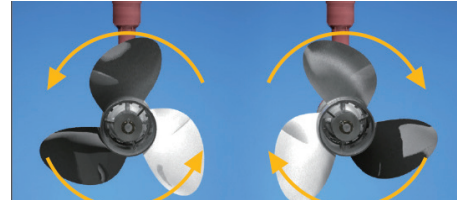

SUZUKI PRECISION CONTROL (Electronic Throttle and Shift Systems)

▶DF350AMD STEALTH ▶DF350AMD/BMD ▶DF350A/300B
▶DF300AP/250AP ▶DF300AP STEALTH ▶DF250ASTEALTH ▶
DF200AP/175AP/150AP ▶DF140BG/115BG

Operation from the remote control is delivered to the outboard via an electric signal and it enables 1 lever operation for up to 6 outboard motors (for dual mount only).

ADVANTAGE

- Reduced friction and resistance compared to the mechanical controls.
- Easy control for multiple outboard motors.
- Improved fuel economy with the combination of Lean Burn Control System.



NOISE REDUCTION

▶DF350AMD/BMD STEALTH ▶DF350A/300B
▶DF200AP/175AP/150AP ▶DF200A/175A/150A
▶DF140BG/115BG ▶DF140B/115B

Intake noise is reduced with silencer and resonator.

ADVANTAGE

- Less noise, makes boating more enjoyable.

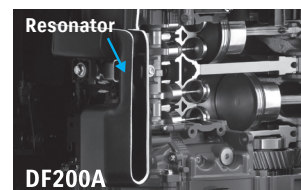

THREE-WAY STORAGE

▶DF6A/4A

The design allows the outboard to be removed from the boat and placed on any of its 3 sides for storage.

ADVANTAGE

- No need to worry about the loading space or method.

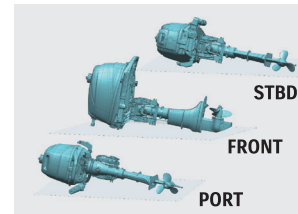

OVERHEAD TANK

▶DF6A/4A

The integral overhead fuel tank and one-way valve delivers fuel supply by using gravity.

ADVANTAGE

- Contributes to easy start.

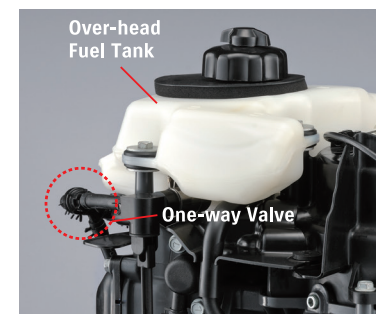

AUTOMATIC TRIM*

▶DF350AMD/BMD ▶DF350A/300B ▶DF300AP/250AP ▶DF300
▶DF200AP/175AP/150AP ▶DF250 ▶DF250A ▶DF250 STEALTH
▶DF200A/175A/150A ▶DF140BG/115BG ▶DF140B/115B
▶V6 DF250/225/200

The Auto Trim feature adjusts the trim angle automatically depending on the engine RPM.



SUZUKI TROLL MODE SYSTEM*

▶DF40A AND UP
Optional for Remote Control Models
Including V6 DF200 DF250/225 with CANbus

This system helps the boat running at a certain speed range in low RPM.

ADVANTAGE

- Boat can keep running at a certain speed range in low RPM without having to operate the throttle on the boat.
- Gives you precise control at low RPM.

*Available with SMD, SMG4, or Troll Mode Switch Panel



SUZUKI EASY START SYSTEM

▶DF40 AND UP
▶Including V6 DF200 DF250/225 with CANbus

Simply turn the key and release, and the starter stays engaged until the engine starts. This system offers a smoother start of the engine.



Integrated Steering System

▶DF350AMD STEALTH / DF300BMD

The conventional external hydraulic cylinder is built into the outboard motor.

ADVANTAGE

- Simple appearance of the motorwell when rigging.
- Allows rigging to various types of boats.
- Easy rigging.

Ecology & Economy



BATTERY-LESS ELECTRONIC FUEL INJECTION

▶DF30A/25A ▶DF20A/15A/9.9B

This technology delivers quicker start, smoother operation, and more acceleration without a battery.

ADVANTAGE

- Operates without battery.
- Quick and easy start.
- Cleaner and economic fuel consumption.
- Higher and smoother performance in almost all operating ranges.

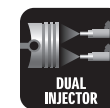

DUAL INJECTOR

▶DF350AMD/300BMD ▶DF350A/300B

The dual injectors deliver just the right amount of fuel at just the right time into each cylinder.

ADVANTAGE

- Contributes to higher output and better fuel efficiency.



LEAN BURN CONTROL SYSTEM

LEAN BURN
▶DF9.9B AND UP
(not including V6 DF250/225/200)

The Lean Burn Control System supplies the appropriate amount of fuel and air mixture depending on the navigation conditions.

ADVANTAGE

- Significant improvement in fuel economy in all speed ranges especially at cruising speed.
- Fuel is saved and gasoline costs are lowered.

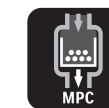

Micro-Plastic Collecting Device

▶DF140BG/115BG ▶DF140B/115B

As one of the actions in SUZUKI CLEAN OCEAN PROJECT, we developed the device to collect micro-plastics in the oceans just by running a SUZUKI's outboard motor.

ADVANTAGE

- Collect micro-plastics through your outboard motors.
- No sacrifice to the engine performance.

STEALTH LINE OUTBOARD MOTORS NEW

DF250A STEALTH / DF250 STEALTH / DF200 STEALTH / DF150 STEALTH / DF115B STEALTH

STEALTH LINE

THE ULTIMATE™
OUTBOARD MOTOR



DF350AMD

DF300AP

DF250A

DF250

DF200A

DF150A

DF140B

DF115B

The Stealth Line Outboard won the 2024 Top Products Award from Boating Industry Magazine for honoring customers and builders demands with an innovative, stylish, bold look.

GOT THE LOOK

DF350 DF300 DF250A

DRIVE BY WIRE

DF250

DF200A / DF150A, DF140B / DF115B

MECHANICAL

BOLD STYLISH QUIET











MATTE BLACK

The "ONE" is characterised by quiet yet robust performance, exhibiting exceptional endurance. Suzuki outboard engines have consistently been described in these terms. Now, the external design of our engines aligns with the high standards set by this renowned engine series.









CHROME BLACK GRAPHICS

Introducing the bold new STEALTH LINE™ of engines from Suzuki Marine, featuring distinctive style lines, a sleek matte black finish, and uncompromising performance. This new lineup solidifies Suzuki Marine as the ultimate choice for outboard motors.







Durability & Reliability

 ANTI CORROSION ALL MODELS	 DUAL LOUVER DF350AMD	 DUAL WATER INLET DF350AMD DF300 STEALTH DF250A	 SELF-ADJUSTING TIMING CHAIN ALL MODELS	 WATER DETECTING SYSTEM ALL MODELS	 TILT LIMIT ALL MODELS	 KEYLESS START SYSTEM (OPTIONAL*1)	 SDSM+ (OPTIONAL)	 DUAL INJECTOR DF350AMD	 LEAN BURN ALL MODELS	 MPC DF140B DF115B
---	--	--	--	---	---	---	--	--	--	--

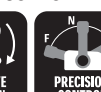
Performance

 2.29 GEAR RATIO DF350AMD	 2.08 GEAR RATIO DF300 STEALTH DF250A	 OFFSET DRIVESHAFT ALL MODELS	 VVT VARIABLE VALVE TIMING DF350AMD DF300 STEALTH DF250A DF200A	 DUAL PROP DF350AMD
 2.50 GEAR RATIO DF200A DF150A	 2.59 GEAR RATIO DF140B DF115B	 MULTI-STAGE INDUCTION DF250 DF200A		

Ease & Comfort

 SELECTIVE ROTATION DF300 STEALTH	 PRECISION CONTROL DF350AMD DF300AP DF250	 TROLL MODE (OPTIONAL*2)	 EASY START SYSTEM ALL MODELS	 NOISE REDUCTION DF350AMD DF200A DF150A DF140B DF115B	 INTEGRATED STEERING SYSTEM DF350AMD	 AUTOMATIC TRIM (OPTIONAL)
--	--	---	--	--	---	---

*1 Available with SMG4

*2 Available with SMG4, or Troll Mode Switch Panel

SPECIFICATIONS / FEATURES P37

V6 350-300HP Flagship - GEKI Series

◆ Drive By Wire DF350AMD / DF300BMD / DF350A / DF300B

THE **ULTIMATE™**
OUTBOARD MOTOR

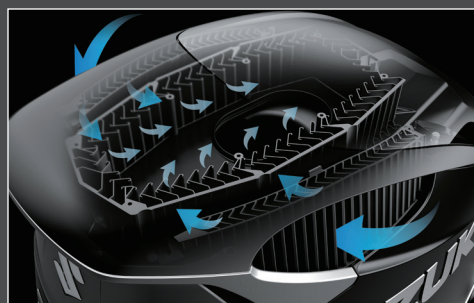

SUZUKI DUAL LOUVER SYSTEM

Dual Louver system is designed to remove water from the air taken into the cowl.

Incorporating a direct intake system makes the highest compression ratio of 12.0:1(DF350AMD,DF350A), 10.5:1(DF300BMD, 300B) possible, ultimately leading to a higher engine output.

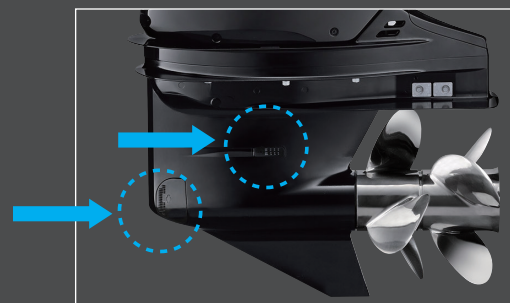

DUAL WATER INLET

The engine's cooling system relies on water supplied through low water intakes located on the lower unit. This dual water inlet configuration increases water flow into the lower unit, delivering greater cooling efficiency.

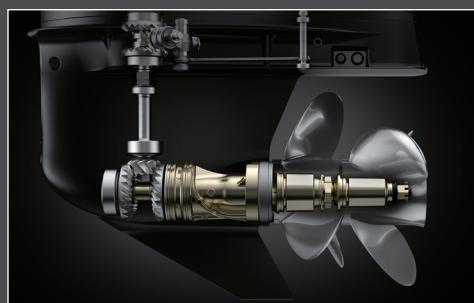

SUZUKI DUAL PROP SYSTEM

The dual prop system efficiently transmits the horsepower into propulsion. As an added benefit, because each propeller rotates in the opposite direction, exceptional stability is achieved.

In addition, the contra-rotating propellers produce a strong reverse thrust.

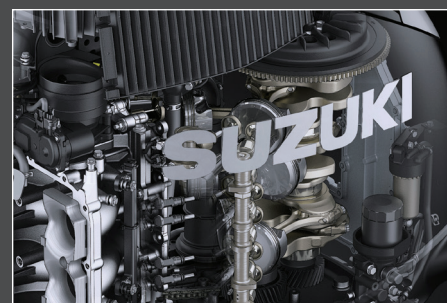

DUAL INJECTOR

Dual injectors deliver just the right amount of fuel at just the right time into the cylinder.

This dual injector contributes to higher output and better fuel efficiency.



DF350AMD

DF300BMD



DF350AMD/ DF300BMD

DF350A/DF300B

DRIVE BY WIRE



GEKI: PARTING SEAS

A Force to Match the Power of Nature and the Sea Representing Suzuki's Identity and Heritage. A Symbol of Our Passion and Commitment to the Ultimate in Marine Innovation.

* "GEKI: PARTING SEAS" is the logo that represents the DF350AMD/DF300BMD, DF350A/DF300B

Durability & Reliability

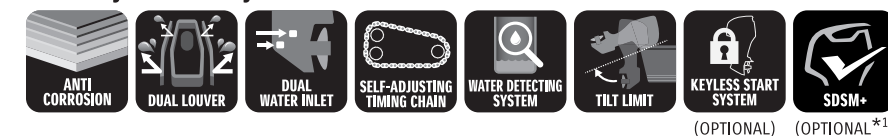

Ecology & Economy

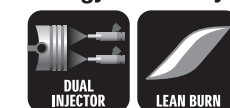

Performance



Ease & Comfort

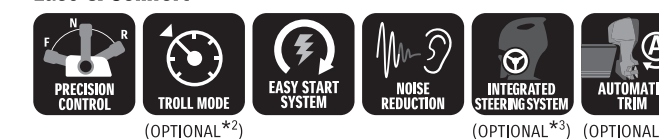

*1 Available with SMG4

*2 Available with SMG4, or Troll Mode Switch Panel

*3 DF350AMD/300BMD

SPECIFICATIONS / FEATURES P36

V6 300-200HP

- ◆ Drive By Wire DF300AP / DF250AP
- ◆ Mechanical DF250 / DF225 / DF200

THE **ULTIMATE**
OUTBOARD MOTOR



DF250 DF225 / DF200

MECHANICAL

STANDARD FEATURES

Durability & Reliability

- ANTI CORROSION ALL MODELS
- SELF-ADJUSTING TIMING CHAIN ALL MODELS
- WATER DETECTING SYSTEM ALL MODELS
- TILT LIMIT ALL MODELS
- SDSM+ (OPTIONAL)*1 ALL MODELS

Performance

- 2.29 GEAR RATIO DF250, DF225, DF200
- 2.08 GEAR RATIO DF300AP, DF250AP
- OFFSET DRIVESHAFT ALL MODELS
- VVT VARIABLE VALVE TIMING DF300AP, DF250AP, DF250
- MULTI-STAGE INDUCTION DF250, DF225

ADDITIONAL FEATURES FOR DRIVE BY WIRE MODEL

Durability & Reliability

- DUAL WATER INLET DF300AP, DF250AP
- KEYLESS START SYSTEM (OPTIONAL) ALL MODELS

Ease & Comfort

- SELECTIVE ROTATION DF300AP, DF250AP
- PRECISION CONTROL DF300AP, DF250AP
- TROLL MODE (OPTIONAL)*2 ALL MODELS
- EASY START SYSTEM ALL MODELS
- AUTOMATIC TRIM (OPTIONAL)*2 ALL MODELS*3

Ecology & Economy

- LEAN BURN DF300AP, DF250AP

DF300AP DF250AP

DRIVE BY WIRE



*1 Available with SMG4 *2 Available with SMG4 or Troll Mode Switch Panel *3 Available for Mechanical using the CAN mechanical harness

Flagsip-GEKI SERIES
V6 300-200HP
IN-LINE 4 200-150HP
IN-LINE 4 140-75HP
IN-LINE 3 60-25HP
PORTABLE 20-2.5HP
STEALTH LINE

IN-LINE 4 200-150HP

- ◆ Drive By Wire DF200AP / DF175AP / DF150AP
- ◆ Mechanical DF200A / DF175A / DF150A

THE **ULTIMATE**
OUTBOARD MOTOR



DF200AP

DF175AP / DF150AP

DRIVE BY WIRE

DF200A

DF175A/DF150A

MECHANICAL

SUZUKI PRECISION CONTROL (S.P.C.) 2.0 (ELECTRONIC THROTTLE AND SHIFT SYSTEMS)

FEATURES

Operation from the remote control is delivered to the outboard motor via an electric signal and it enables the one lever operation for up to 6 outboard motors (for dual mount only).



SUZUKI SELECTIVE ROTATION

P10

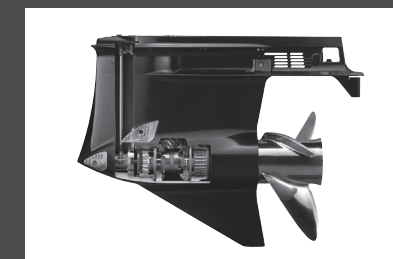

Function for selecting standard or counter rotation on one outboard with an optional connector.

NOISE REDUCTION

P10

Intake noise is reduced with a resonator, that lowers sound levels and improves the boating experience.

STANDARD FEATURES

Durability & Reliability

- ANTI CORROSION: ALL MODELS
- SELF-ADJUSTING TIMING CHAIN: ALL MODELS
- WATER DETECTING SYSTEM: ALL MODELS
- TILT LIMIT: ALL MODELS
- SDSM+: (OPTIONAL)*1 ALL MODELS
- KEYLESS START SYSTEM: (OPTIONAL) ALL MODELS

Ease & Comfort

- NOISE REDUCTION: ALL MODELS
- TROLL MODE: (OPTIONAL)*2 ALL MODELS
- EASY START SYSTEM: ALL MODELS
- AUTOMATIC TRIM: (OPTIONAL)*2 ALL MODELS

Ecology & Economy

- LEAN BURN: ALL MODELS

Performance

- OFFSET DRIVESHAFT: ALL MODELS
- 2.50 GEAR RATIO: ALL MODELS
- MULTI-STAGE INDUCTION: ALL MODELS
- VVT VARIABLE VALVE TIMING: Not including DF150A

ADDITIONAL FEATURES FOR DRIVE BY WIRE MODEL

Ease & Comfort

- SELECTIVE ROTATION: DF200AP, DF175AP, DF150AP
- PRECISION CONTROL: DF200AP, DF175AP, DF150AP

*1 Available with SMG4

*2 Available with SMG4, or Troll Mode Switch Panel

SPECIFICATIONS / FEATURES P37

IN-LINE 4 140-75HP

- ◆ Drive By Wire DF140BG / DF115BG
- ◆ Mechanical DF140B / DF115B / DF90A / DF75A

THE **ULTIMATE**
OUTBOARD MOTOR

COLLECT MARINE MICRO-PLASTIC WASTE

As a solution to the plastics flowing into the oceans, which are not collected properly on land, Suzuki developed the world's first Micro-Plastic Collecting (MPC) device installed on outboard motors.

BEFORE 22 MODEL YEAR

WITH MICRO-PLASTIC COLLECTING DEVICE

Garbage-contaminated seawater

Microplastic collector makes the sea beautiful

Collected materials

FEATURES

- Will not affect the performance of the engine even if the filter gets clogged since this device utilizes the used cooling water.
- Will not negatively affect the environment.

STANDARD FEATURES

Durability & Reliability

ALL MODELS	ALL MODELS	ALL MODELS	ALL MODELS	(OPTIONAL*) ALL MODELS	(OPTIONAL) ALL MODELS	(OPTIONAL) ALL MODELS

Ease & Comfort

(OPTIONAL*) REMOTE CONTROL MODELS (STANDARD) TILLER HANDLE MODELS	ALL MODELS	DF140BG/DF115BG, DF140B/DF115B, DF100C	(OPTIONAL*) DF140BG/115BG, DF140B/115B/100C

Performance

ALL MODELS	ALL MODELS

Ecology & Economy

ALL MODELS	DF140BG/DF115BG, DF140B/DF115B, DF100C

ADDITIONAL FEATURES FOR DRIVE BY WIRE MODEL

Ease & Comfort

DF140BG, DF115BG

*1 Available with SMG4 *2 Available with SMG4, or Troll Mode Switch Panel

SPECIFICATIONS / FEATURES P38



DF140BG
DF115BG

DRIVE BY WIRE

with MPC



DF140B
DF115B

MECHANICAL

with MPC



DF90A
DF75A

MECHANICAL

■ Tiller handle model available (For 90HP & 75HP)

IN-LINE 3 60-25HP

DF60AV / DF50AV
DF60A / DF50A / DF40A
DF30A / DF25A

THE **ULTIMATE**
OUTBOARD MOTOR



HIGH ENERGY ROTATION

These outboards are equipped with a 2.42 gear ratio, which is larger than the standard model. When combined with a large 36cm (14-inch) propeller, the system can deliver powerful thrust. This is ideal for heavy boats.

ADVANTAGE

- Powerful propulsion and precise maneuvering, even with heavy loads.
- Superior power to turn large diameter propellers.

DF60AV vs. DF60A size comparison

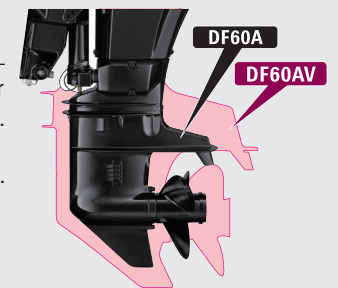

	DF60AV	DF60A
Gear Ratio	2.42	2.27



SELF-ADJUSTING TIMING CHAIN

The timing chain running in an oil-bath is adjusted automatically by a hydraulic tensioner.

ADVANTAGE

- More durable than the belt type.
- Maintenance-free.



BATTERY-LESS Electronic Fuel Injection

P11

This technology delivers quick start, smooth operation, and strong acceleration without a battery.

TROLL MODE + SMG4

P30



Allows you to control your troll mode from the Multi-Function Gauge.



DF60AV
DF50AV

HIGH ENERGY ROTATION

■ Tiller handle available



DF60A
DF50A / DF40A

■ Tiller handle available

STANDARD FEATURES

Durability & Reliability

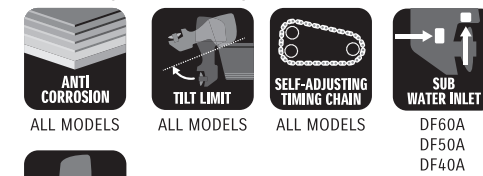

Performance Ease & Comfort



Ecology & Economy



DF60AV (OPTIONAL *2)
DF50AV ALL MODELS

*1 Available with SMG4

*2 Available with SMG4, or Troll Mode Switch Panel



DF30A
DF25A

BATTERY-LESS EFI

- Gas assist model available
- Remote Control model available
- Power Trim and Tilt available



STANDARD FEATURES

Durability & Reliability



Ecology & Economy



*1 Available with SMG4

SPECIFICATIONS / FEATURES P38

PORTABLE 20-2.5HP

DF20A / DF15A / DF9.9B
DF6A / DF4A
DF2.5

THE **ULTIMATE**
OUTBOARD MOTOR



INTEGRAL OVERHEAD FUEL TANK

The integral overhead fuel tank and one-way valve delivers fuel supply using gravity.

THREE-WAY STORAGE

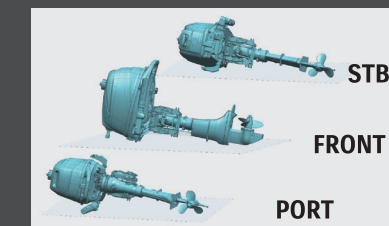

The design allows the outboard to be removed from the boat and placed on any of its 3 sides for storage.

STANDARD FEATURES

Durability & Reliability

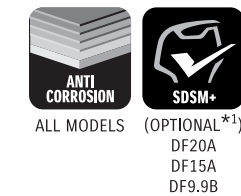

Ease & Comfort

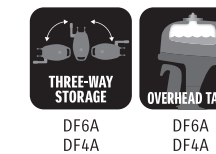

Ecology & Economy

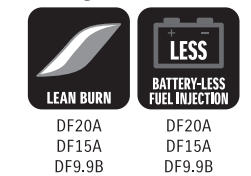

*1 Available with SMG4



DF20A

DF15A / DF9.9B

BATTERY-LESS EFI

- Remote control model available
- Power Trim and Tilt available
- Electric Start available



DF6A

DF4A

THREE-WAY STORAGE



DF2.5

Flagship-GEKI SERIES

V6 300-200HP

IN-LINE 4 200-150HP

IN-LINE 4 140-75HP

IN-LINE 3 60-25HP

PORTABLE 20-2.5HP

STEALTH LINE

SPECIFICATIONS / FEATURES P39

PARTS & ACCESSORIES

SUZUKI MULTI-FUNCTION GAUGE (SMG4) ▶DF9.9B AND UP

Suzuki Multi-Function Gauge provides all performance information on one gauge. Individual elements can also be emphasized to further enhance user friendliness.

SMG4



DAY MODE



NIGHT MODE

FEATURES



MULTI-LINGUAL MENU



AUTOMATIC TRIM FUNCTION

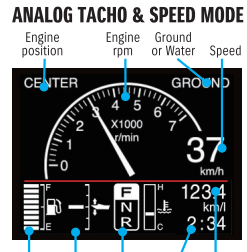

ANALOG TACHO & SPEED MODE



TROLL MODE

SPECIFICATIONS

- 3.5 Color Display
- Size: 4.13 in. (W) x 4.13 in. (H) x 0.63 in. (D)
- NMEA2000 output
- Shows both digital and analog readouts, as well as day/night mode
- Displays the QR code* for SDSM / SDSM+
- Troll Mode Function: Allows user to control troll mode (only for 2019MY and newer models adapted to troll mode)

English, French, Italian, German, Spanish, Swedish, Norwegian, Finnish, Dutch, Portuguese, Danish, Russian, Japanese

Automatically adjusts trim angle.

* DENSO WAVE owns the rights of the name and the logo of QR code.

FURUNO FishHunter™ Drive

FishHunter™ Drive delivers all-new control features for boaters utilizing select Suzuki outboard models driven by the Furuno NAVpilot-300 Autopilot. these unique Suzuki features include Speed Control, Point Lock™, Route Smoothing™, and Sabiki Lock™.



Applicable Models : All SPC models (DF350AMD/300BMD, DF350A/300B, DF300AP/250AP, DF200AP/175AP/DF150AP, DF140BG/115BG)

WATERGRIP PROPELLER

WATERGRIP is a stainless-steel propeller series offering accurate response to your operation. With this propeller series efficiently converts engine power into propulsion, and meets our customers' demand for bigger, faster, more powerful outboards.

The WATERGRIP propeller series employs a new interchangeable and square shaped propeller bushing that minimizes power loss in delivery.

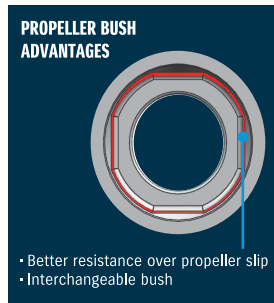

- Better resistance over propeller slip
- Interchangeable bush

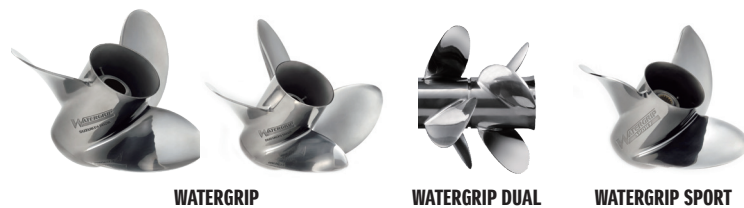

WATERGRIP

WATERGRIP DUAL

WATERGRIP SPORT

MULTI-FUNCTION TILLER HANDLE ▶DF115B ▶DF75A/90A ▶DF60A/50AV/60AV ▶DF40A/50A

Main features

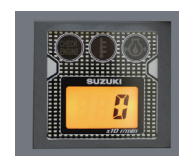

Tachometer* with warning indicators



Three-position angle adjustable bracket



Troll mode switch* - Activates SUZUKI Troll Mode System and controls RPM from idling engine speed up to 1200rpm at every 50rpm.



Power trim & tilt switch* and throttle grip friction adjuster

SUZUKI PRECISION CONTROL FOR DRIVE-BY-WIRE SYSTEM

▶DF350AMD/300BMD ▶DF350A/300B ▶DF300AP/250AP ▶DF200AP/175AP/150AP ▶DF140BG/115BG ▶DF250A STEALTH ▶DF300 STEALTH

Suzuki's best technology lies in the Suzuki Precision Control (S.P.C.) for Drive-By-Wire System. The S.P.C. enables instant, precise throttle response for greater control and accuracy.

FEATURES

- Control up to 6 outboard engines.
- Sequential start for multi-engine boats: Engines start in order from port to starboard.
- Automatic Trim is available with SMD or SMG4.
- 1 Lever Operation : This switch allows multiple engine operation with just 1 lever. (Dual top mount only)
- Integrated Emergency Switch (Flush Mount only)

REMOTE CONTROL BOX

Integrated "Select" and "Throttle Only" switch (All)



SUZUKI BINNACLE

DUAL BINNACLE

FLUSH MOUNT BINNACLE

CONTROL PANEL



SWITCH PANEL FOR REGULAR KEY



KEYLESS START SYSTEM*

- ▶ All S.P.C. models and DF200A/175A/150A ,DF140B/115B, DF90A/75A
- ▶ Available for all Mechanical models DF70-Up using the CAN Mechanical Harness

How to use

1. Stand nearby the console with the key fob.
2. Push START/STOP button to start engine.
3. To turn off the engine, push the button again.

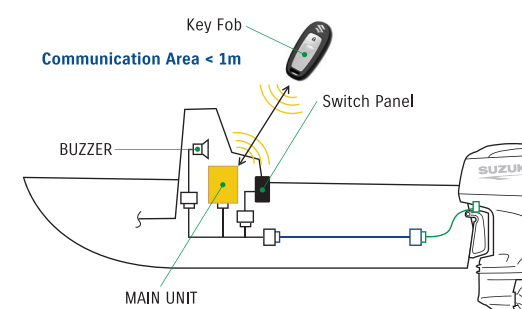

Find out more by watching our videos

*Please check applicability with your local Suzuki dealer.

FEATURES

- 3 types of panels are available: Vertical, Horizontal and Individual.
- 1-push Start/Stop, and controls up to 6 engines. No ignition key necessary.



Find out more from our video

MAINTENANCE KITS

Suzuki provides maintenance kits for quick and reliable service. Each kit comes with all the specific maintenance parts necessary for your model.

Please consult your local Suzuki dealer for the contents of each kit and applicable models.



PARTS & ACCESSORIES

SUZUKI DIAGNOSTIC SYSTEM MOBILE PLUS (SDSM+)

DF9.9B AND UP
*Available with SMG4

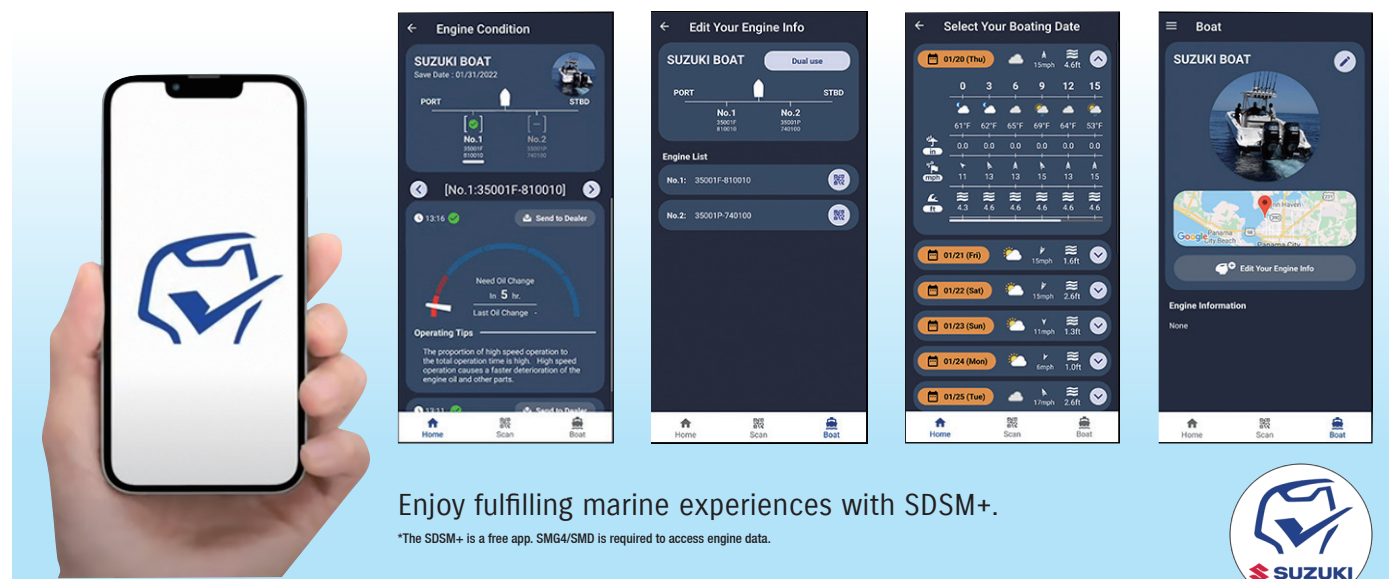

Enjoy fulfilling marine experiences with SDSM+.

*The SDSM+ is a free app. SMG4/SMD is required to access engine data.



3 FEATURES OF THE SDSM+

1. PLAN A BOAT TRIP WITH THE FORECAST

- + You can make a boating plan and refer to the weather, wind, and wave condition at a designated point.
- + The app also shows the weekly weather forecast, which is constantly updated.

2. INSPECT BOAT AND OUTBOARD MOTOR IN ADVANCE

- + Outboard motor can be checked based on the engine data.
- + You can share engine data with your dealer, which can shorten the service time.

3. ACQUIRE ENGINE DATA

- + You can check the engine condition and your driving tendencies.
- + You can provide engine data to your dealer, to check engine maintenance reminders.



Apple and the Apple logo are trademarks of Apple Inc., registered in the U.S. and other countries. App Store is a service mark of Apple Inc., registered in the U.S. and other countries.



Google Play and the Google Play logo are trademarks of Google LLC.

HOW TO GET THE ENGINE DATA

1. The outboard will convert engine data into a QR code* displayed on the SMG4 or SMD.
2. Open the app and scan the QR code. The app will receive the engine data and automatically attach it to an e-mail.
3. You can then send the e-mail to your nearby dealer to shorten the maintenance time.

*DENSO WAVE owns the rights of the name and the logo of QR code.



Find out more at our Global Website

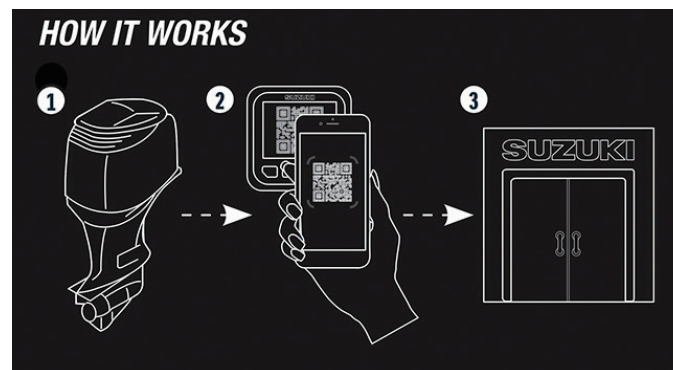

ECSTAR

GENUINE OIL & CHEMICAL

What is ECSTAR

ECSTAR is a global brand name of SUZUKI Genuine Oil & Chemicals.

The ULTIMATE Formulation

Suzuki Approved Genuine engine oils have all been rigorously tested and certified by Suzuki engineers. You can be confident that they'll help keep your Suzuki outboard in perfect condition, giving you maximum performance and reliability over its lifetime.

ECSTAR Line up for OUTBOARD MOTORS

ENGINE OIL
SEMI SYNTHETIC V7000



GEAR OIL
SAE90



WATER RESISTANT
GREASE



Availability may differ in some regions. Please contact your Suzuki local dealer.

SPECIFICATIONS & FEATURES

SPECIFICATIONS	350AMD	300BMD	350A	300B	300AP	250AP	250	225	200
STARTING SYSTEM	Electric		Electric		Electric		Electric		
RECOMMENDED TRANSOM HEIGHT in	L: 20 X: 25 XX: 30		X: 25 XX: 30		L: 20 ² X: 25 XX: 30		X: 25 XX: 30	X: 25	L: 20 X: 25 XX: 30
WEIGHT lbs	L: 761 X: 776 XX: 794		X: 728 XX: 745		L: 626 X: 639 XX: 659		X: 606 XX: 626	X: 606	L: 582 X: 606 XX: 626
VALVE TRAIN	DOHC 4 Valves		DOHC 24-Valve		DOHC 24-Valve		DOHC 24-Valve		
VALVE TRAIN DRIVE	Chain		Chain		Chain		Chain		
DISPLACEMENT in³	267.9		267.9		245.6		220.5		
MAXIMUM OUTPUT HP	350	300	350	300	300	250	250	225	200
BORE & STROKE in	3.86 x 3.81		3.86 x 3.81		3.86 x 3.50		3.74 x 3.35		
OPERATION RANGE rpm	5,700-6,300	5,300-6,300	5,700-6,300	5,300-6,300	5,700-6,300	5,500-6,100	5,500-6,100	5,000-6,000	5,000-6,000
FUEL DELIVERY SYSTEM	Electronic Fuel Injection		Electronic Fuel Injection		Electronic Fuel Injection		Electronic Fuel Injection		
OIL PAN CAPACITY QTS	8.4		8.4		8.4		8.4		
ALTERNATOR	12V 54A		12V 54A		12V 54A		12V 54A		
TRIM TYPE	Power Trim and Tilt		Power Trim and Tilt		Power Trim and Tilt		Power Trim and Tilt		
GEAR RATIO	2.29:1		2.29:1		2.08:1		2.29:1		
CONTROL SYSTEM	Digital		Digital		Digital		Mechanical		
RECOMMENDED FUEL	89 Octane 87 Octane		89 Octane 87 Octane		89 Octane		87 Octane		
PROPELLER SELECTION (PITCH)	12"-31.5"		12"-31.5"		17"-26"		17"-26"		

All propellers are the 3-blade type. Please inquire at your local dealer for details of the propeller.
*1: Dry Weight: Including battery cable, not including propeller and engine oil. *2: DF300AP only

250A STEALTH	250 STEALTH	200 STEALTH	150 STEALTH	140B STEALTH	115B STEALTH	200AP	175AP	150AP	200A	175A	150A
Electric						Electric			Electric		
L: 20 X: 25						L: 20 X: 25			L: 20 X: 25		
L: 626 X: 639	L: 578 X: 606	L: 518 X: 529	L: 518 X: 529	L: 410 X: 419	L: 415 X: 423	L: 520 X: 531			L: 518 X: 529		
DOHC 4 valves per cylinder						DOHC 16-Valve			DOHC 16-Valve		
Chain						Chain			Chain		
245.6		175.0	175.0	124.7	124.7	175			175		
250		200	150	140	115	200	175	150	200	175	150
3.81 x 3.46	3.81 x 3.46	3.81 x 3.81		3.40 x 3.50	3.40 x 3.50	3.8 x 3.8			3.8 x 3.8		
5,500-6,300	5,500-6,300	5,500-6,100	5,000-6,000	5,600-6,200	5,600-6,000	5,500-6,100	5,000-6,000	5,500-6,100	5,000-6,000	5,500-6,100	5,000-6,000
Electronic Fuel Injection						Electronic Fuel Injection			Electronic Fuel Injection		
8.0						8.4			8.4		
12V 54A		12V 44A		12V 40A		12V 44A			12V 44A		
Power Trim and Tilt						Power Trim and Tilt			Power Trim and Tilt		
2.08:1		2.5:1		2.59:1		2.50:1			2.50:1		
Remote						Digital			Mechanical		
87 Octane						87 Octane			87 Octane		
17"-30"				9"-26"		17"-26"			17"-26"		

All propellers are the 3-blade type. Please inquire at your local dealer for details of the propeller.
*1: Dry Weight: Including battery cable, not including propeller and engine oil. *2: DF300AP only

FEATURES

		350AMD	300BMD	350A	300B	300AP	250AP	250	225	200
BODY COLOR	Black	●	●	●	●	●	●	●	●	●
	Stealth	●	●							
	White	●	●	●	●	●	●	●	●	●
INTEGRATED STEERING		●								
SUZUKI DUAL LOUVER SYSTEM		●	●	●	●					
SELF ADJUSTING TIMING CHAIN		●	●	●	●	●	●	●	●	●
SUZUKI ANTI-CORROSION SYSTEM		●	●	●	●	●	●	●	●	●
OVER-REV. LIMITER		●	●	●	●	●	●	●	●	●
TILT LIMIT SYSTEM		●	●	●	●	●	●	●	●	●
WATER DETECTING SYSTEM		●	●	●	●	●	●	●	●	●
FRESH WATER FLUSHING SYSTEM		●	●	●	●	●	●	●	●	●
DUAL WATER INLET		●	●	●	●	●	●			
SUB WATER INLET										
NEW KEYLESS START SYSTEM		○	○	○	○	○	○	○	○	○
SDSM^{*1}		○	○	○	○	○	○	○	○	○
OFFSET DRIVESHAFT		●	●	●	●	●	●	●	●	●
2-STAGE GEAR REDUCTION		●	●	●	●	●	●	●	●	●
HIGH ENERGY ROTATION										
SUZUKI DUAL PROP SYSTEM		●	●	●	●					
VARIABLE VALVE TIMING		●	●	●	●	●	●	●	●	●
MULTI-STAGE INDUCTION								●	●	
SUZUKI SELECTIVE ROTATION						●	●			
SUZUKI PRECISION CONTROL		●	●	●	●	●	●			
NOISE REDUCTION		●	●	●	●					
OVERHEAD TANK										
AUTOMATIC TRIM^{*2}		○	○	○	○	○	○	○	○	○
GAS ASSIST SYSTEM										
THREE-WAY STORAGE										
SUZUKI TROLL MODE SYSTEM^{*2}		○	○	○	○	○	○	○	○	○
SUZUKI EASY START SYSTEM		●	●	●	●	●	●	●	●	●
LEAN BURN CONTROL SYSTEM		●	●	●	●					
DUAL INJECTOR		●	●	●	●	●	●			
O₂ SENSOR FEEDBACK CONTROL SYSTEM										
SHALLOW WATER DRIVE										

*1: available by using with SMD/SMG4 *2: available by using with SMD/SMG4/Troll Mode Switch Panel *3: available by using with SMG4/SMD, and New S.P.C.

250A STEALTH	250 STEALTH	200 STEALTH	150 STEALTH	115B STEALTH	200AP	175AP	150AP	200A	175A	150A
					●	●	●	●	●	●
●	●	●	●	●						
					●	●	●	●	●	●
●	●	●	●	●	●	●	●	●	●	●
●	●	●	●	●	●	●	●	●	●	●
●	●	●	●	●	●	●	●	●	●	●
●	●	●	●	●	●	●	●	●	●	●
●	●	●	●	●	●	●	●	●	●	●
○		○	○	○	○	○	○	○	○	○
○	○	○	○	○	○	○	○	○	○	○
●	●	●	●	●	●	●	●	●	●	●
●	●	●	●	●	●	●	●	●	●	●
					●	●	●	●	●	●
○	○	○	○	○	○	○	○	○	○	○
●	●	●	●	●	●	●	●	●	●	●
					●	●	●	●	●	●

●=Standard Equip. ○=Optional Equip.

HISTORY

THE
ULTIMATE™
OUTBOARD MOTOR

Continuously evolving over the decades, Suzuki has a rich, proud history knowing no bounds.

SUZUKI A HISTORY OF OUTBOARD INNOVATION

Yamaika Spirit
"Let's give it a try."



1965
D55

SUZUKI'S FIRST
OUTBOARD MOTOR

EARLY OIL
INJECTION ENGINES

DT25
1974



1980
DT85

WINNER NMMA
MOST INNOVATIVE
PRODUCT AWARD

DT200
EXANTE
1987



1997
DF70

INDUSTRY-FIRST
4-STROKE WITH EFI
NMMA INNOVATION
AWARD WINNER



INDUSTRY-FIRST V6
300 HP 4-STROKE

NMMA INNOVATION
AWARD WINNER

DF300
2006

DF200 ADOPTS
SUZUKI SELECTIVE ROTATION
AND DELIVERS BIG BLOCK
PERFORMANCE FROM
AN INLINE 4 ENGINE

DF200AP
2014



2017
DF350A

FIRST OUTBOARD
CONTRAROTATIONAL
DUAL PROP. SYSTEM

NMMA INNOVATION
AWARD WINNER

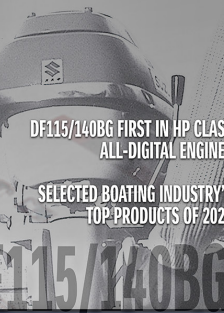

DF115/140BG FIRST IN HP. CLASS
ALL-DIGITAL ENGINES

SELECTED BOATING INDUSTRY'S
TOP PRODUCTS OF 2021

DF115/140BG
2020



2024
STEALTH

SUZUKI INTRODUCES AND EXPANDS
A BOLD NEW STYLE AND
APPEARANCE THAT EMBODIES
QUIET, STRONG PERFORMANCE AND
EXCEPTIONAL ENDURANCE

SELECTED BOATING INDUSTRY'S
TOP PRODUCTS OF 2024



Please read your Owner's Manual carefully. Remember, boating and alcohol or other drugs don't mix. Always wear a personal flotation device when boating. Please operate your outboard safely and responsibly.

Suzuki encourages you to operate your boat safely and with respect for the marine environment.

Specifications, appearances, equipment, colors, materials and other items of "SUZUKI" products shown in this catalogue are subject to change by manufacturers at any time without notice and they may vary depending on local conditions or requirements. Each model might be discontinued without notice. Please enquire at your local dealer for details of any such changes. Actual body color might differ from the colors in this brochure.



Suzuki Marine USA, LLC
13521 Prestige Pl.
Tampa, FL 33685-2529
www.suzukimarine.com

FULL LINE CATALOG
99953-25501
Printed in the U.S.A.

©2025 Suzuki Marine USA, LLC. All rights reserved.

